

Advanced Stand-alone Tester for Insulation Assessment

DAC-STM-1

This instrument is a standalone and movable AC insulation test system containing a built-in high-voltage testing power supply. Simplified and automated operation and wiring are realized, and the time for setting and measurement can be greatly reduced, strongly supporting on-site

■ Application

- Performance and Maintenance Test of Power Transformers
- Factory test of Railway Motors
- Maintenance Test of Generators and Motors
- Insulation Oil and Materials Test

■ Specimen

- Power Transformers
- Power Cables
- Generators, Motors, Rotators and Bar Coils
- Capacitors, Insulators and Bushings
- Insulation Oil and Materials

■ Measuring Parameters

- $\tan\delta$
- P.F.
- Capacitance
- Inductance



DAC-STM-1

Advanced Stand-alone Tester for Insulation Assessment of Motor / Generator / Transformer

DAC-STM-1 is a standalone and movable test system in one box providing a built-in high-voltage testing power supply. Simplified operations and automatic testing mode change are realized, that is, setting and measuring time can be greatly reduced.

Compact in size for testing site, Low center of gravity, it is designed to be very stable and easily even moving with only two wheels. DAC-STM-1 strongly supports to complete quickly your on-site measurement.

Features

- This instrument has a built-in testing power supply, and is easy to move and set connections, enabling quick setup and start measurement in a moment.
- Introducing high voltage CT method, reliable measurement without being affected by stray current in grounding.
- Providing a change circuit of UST, GST and GSTg mode, automatic measurement through the three mode can be quickly done without changing connections
- Applicable to a transformer with Tertiary winding.
- Providing Induced Emission and Polarity Change, advantageous to test on sites where are prone to inductive interference.

UST, GST, GSTg change circuit inside

Conventionally, measuring cables have to be changed in accordance with testing modes. However DAC-STM-1 is provided with a change circuits that automatically change C_{H-L} , C_{H-T} or C_{H-G} .

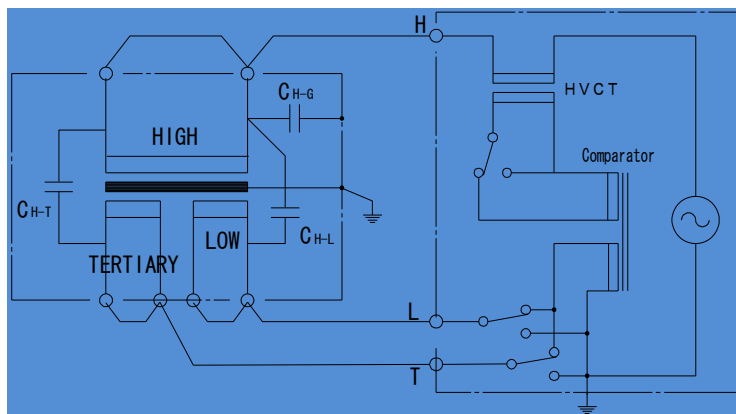

Power Transformer

DAC-STM-1

- C_{H-L} WITH GUARD-T
- C_{H-T} WITH GUARD-L
- $C_{H-L} + C_{H-T}$ NO GUARD
- $C_{H-G} + C_{H-L} + C_{H-T}$ NO GUARD
- $C_{H-G} + C_{H-L}$ WITH GUARD-T
- $C_{H-G} + C_{H-T}$ WITH GUARD-L
- C_{H-G} WITH GUARD-T+L

Effective Transformer Bridge Measuring Method

Absolute Measurement

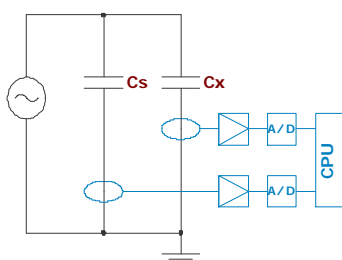

Transformer Bridge

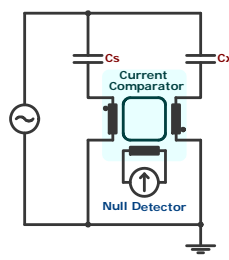

- In the absolute measuring method, detecting the current of C_s and C_x with different CTs, this method is not affected by stay currents, but the measurement accuracy is lower than that of the null detection. Moreover, noise elimination generating from the power supply is required, and unstable frequency moving may cause measuring errors.
- In the transformer bridge measuring method, the low potential side has no impedance. Negligible stray capacitor affect, Guarding at ground potential, thus high accurate measurement.



Cable Connection

Measuring cable with rock type connector can help your on-site test to be done smoothly and safely.

LCD Display Touch-Screen Panel



High Resolution Large LCD display (8.4inches) is introduced, Easy to see visibly in outdoor field tests.

All operations are in touch. Testing Voltage and Measuring Range as well as Auto or Manual mode are also available from the display. Measured Data can be given very well in response on the display.

USB Memory Save USB Version 2.0 Connector

Measured Data can be saved to USB memory in CSV file. Data are saved automatically in a HV Transformer Automatic Measuring Mode, while it is saved optionally in a manual measuring mode, oil measuring mode and Inductance measuring mode.

Induced Voltage Interference Elimination

Before applying testing voltage, induced currents are detected to eliminate automatically.

PC Software

USB interface comes as standard, the set can be controlled by a PC. An exclusive software allow DAC-STM-1 to obtain data in a test, $V - \tan\delta$ test.

Manual Measurement

Transformer Measurement

CSV output

SOKEN Original Precious High Potential Current Transformer Method

Introducing a high potential Current Transformer designed originally by SOKEN to detect measuring signals, measuring error factors as colored in red do not come in the detecting CT, and only the signals can be detected to measure tan delta and power factors accurately.

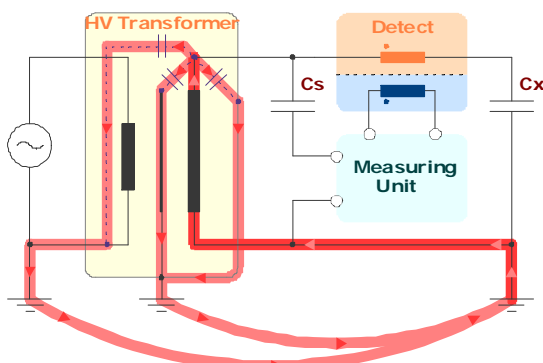

- Stray Currents, generated by floating capacitance between high potential sides and grounds, do not come in the detecting CT. Thus, the method is free from measuring error factors.
- Stray Currents, flowed through ground lines by induced voltages generating between grounds, do not come in the detecting CT. Thus, the method is free from measuring error factors.

Specifications

- tanδ 0.00 – 100 %
- P.F. 0.00 – 70 %
- Capacitance 100pF – 100nF/12kV, 50pF–50nF/1kV, 100nF–1uF/100V
- Inductance 10.0H – 10000H
- Testing Voltage 100V–12kV / 10V–1200V (1uF range, Oil Test Mode)
- Test Current 0.01mA–1A
- Testing Frequency 50/60Hz line
- Output Current 83.3mA continuous / 12kV
- Output Power 1kVA continuous / 2kVA 60 minutes/3kVA 8 minutes
- Built-in STD Capacitor 500pF±10% / tanδ <0.02%
- Input Power 100–120VAC (or 200–240VAC), 50/60Hz
- Size W452xH994xD312mm (no projections)
- Weight approx. 80kg
- Working Temperature -10°C–50°C
- Working Humidity 5% – 95%r.h. (no dew)
- Accessories Measuring Cable x 3, AC Cord x 1, Grounding Cable x 1, Accessories Bag, Warning Lamp

Resolution/Measuring Accuracy (at 20 degree C)

Parameter	Range	Resolution	Measuring Accuracy
tanδ	2%	0.01%	±(0.02%+3%Rdg+1Digit)
	20%	0.1%	
	100%	1%	
P.F. (cosθ)	2%	0.01%	±(0.02%+3%Rdg+1Digit)
	20%	0.1%	
	100%	1%	
Capacitance	500pF	0.1pF	±(0.3%Rdg+1Digit)
	5nF	0.001nF	
	50nF	0.01nF	
Inductance	10000H	10H	±(0.5%Rdg+1Digit)
	1000H	1H	
	100H	0.1H	
Output Voltage	100V–12kV	0.1kV	±(1%Rdg+1Digit)
	10V–1200V	1V	
Test Current	0.01mA–1A	0.001mA	±(1%Rdg+1Digit)
Watt Loss	0–1000W	0.0001W	±(2%Rdg+2Digit)
Frequency	45–70Hz	0.1Hz	±(0.1%Rdg+1Digit)



Measuring Mode

- HV Trans Auto Test Mode
- Manual Test Mode
- Oil Test Mode
- Inductance Test Mode

Size(mm)

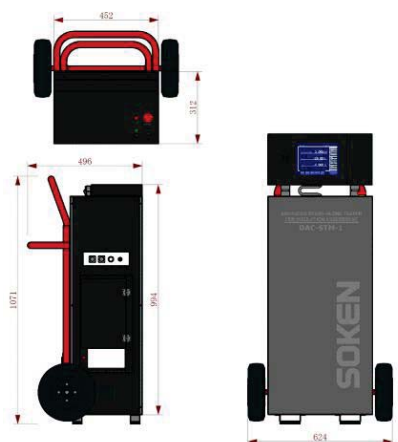

Functions

- Induced Interference Suppression
- Polarity Change
- USB Communication Control
- USB Memory Save
- GTS and UTS Selection Switch

SOKEN
ELECTRIC CO.,LTD.

1-34-22, Tobitakyu, Chofu
Tokyo 182-0036
JAPAN

TEL: 81 42 490 6929(Export Dept)
FAX: 81 42 490 6807
✉: s2258@soken-jp.com
www.soken-jp.com



ISO 9001:2008